



DATASHEET:

HA-OL2 & HA-OL2R

DOUBLE OBSTRUCTION LIGHT

Two HA-OL obstruction lights are mounted on a bull horn. ICAO low intensity for obstructions/obstacles up to 45 meters/150 feet. The HA-OL2R is a double obstruction light with an automatic relay. If the main light fails, the standby light will automatically switch on.

ENCLOSURE	Heavy aluminium body, colour: yellow RAL 1021, chromate conversion and powder coating
DIMENSIONS	Ø255x146x280mm
WEIGHT	3,5 kg
LENS	Borosilicate glass tempered (Red)
MOUNTING	3/4" threading
LIGHT SOURCE	LED
POWER CONSUMPTION	2x5 watt
EXPECTED LIFETIME	>75.000 hours
POWER SUPPLY	110-240VAC or 50/60 Hz
LIGHT OUTPUT	>50 cd suitable for ICAO Class A >10 cd and ICAO Class B >32,5 cd
AMBIENT TEMPERATURE	-40 °C to + 50 °C
INGRESS PROTECTION	IP 65
COMPLIANCES	ICAO Annex 14 Vol. II UK CAP 437
HS CODE (CUSTOMS TARIFF)	94054031

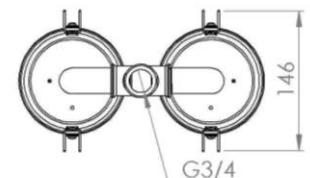
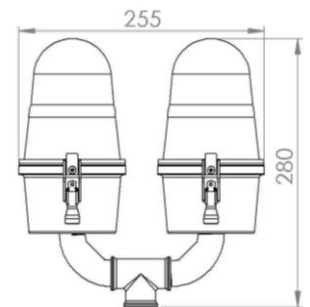
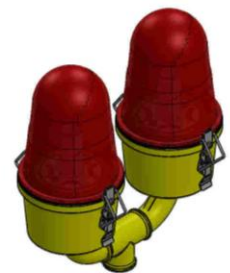

Holland Aviation
Daniëlsweg 40
4451 HW Heinkenszand
The Netherlands

Tel. +31 (0)113 613467
Fax. +31 (0)113 613570
Email: info@hollandaviation.com
www.hollandaviation.com

