



DATASHEET:

## HA-OSH 11 OBSTRUCTION LIGHT

### LED TECHNOLOGY ATEX ZONE 2

HA-OSH 11-32 or HA-OSH 11-50 is a low-intensity obstruction light to denote obstacles up to 45 meters/150 feet .

**ENCLOSURE** Aluminium body, colour: yellow RAL 1021, chromate conversion and powder coating

**DIMENSIONS** 160 x 240 x 175 mm

**WEIGHT** 4,5 Kg

**LENS** Borosilicate glass tempered (Red)

**CABLE GLAND** 2x M20 standard

**LIGHT SOURCE** High power LED

**POWER CONSUMPTION** 5 watt

**EXPECTED LIFETIME** >75.000 hours

**POWER SUPPLY** Multi voltage power supply

90-264VAC 50/60 Hz

110-370VDC 50/60 Hz

**LIGHT OUTPUT** ICAO Class A >10 cd and ICAO Class B >32,5 cd and >50 cd (Dutch aviation authority)

**AMBIENT TEMPERATURE** -40 °C to + 60 °C

**INGRESS PROTECTION** IP 66

**OPTIONS** -Flashing 30, 60, 90 or 120 Fpm (factory set)

-Other input voltages

**COMPLIANCES** ICAO Annex 14 Vol. II

UK CAP 437

Atex zone 2 ATEX II 3 G Ex nA IIC T5

EASA ADR

**HS CODE (CUSTOMS TARIFF)** 94054031

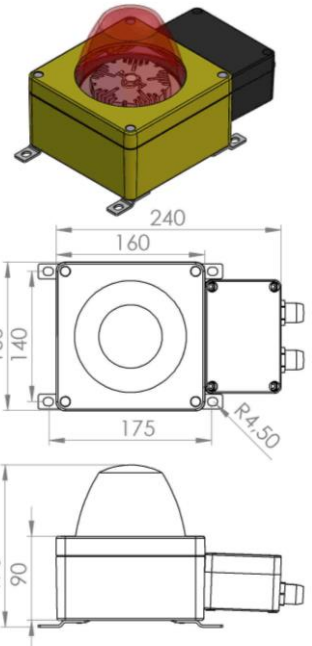

Holland Aviation  
Daniëlsweg 40  
4451 HW Heinkenszand  
The Netherlands

Tel. +31 (0)113 613467  
Fax. +31 (0)113 613570  
Email: [info@hollandaviation.com](mailto:info@hollandaviation.com)  
[www.hollandaviation.com](http://www.hollandaviation.com)

